

(12) PATENT
(19) AUSTRALIAN PATENT OFFICE

(11) Application No. AU 199641200 B2
(10) Patent No. 704594

(54) Title
Production of recombinant peptides as natural hydrophobic peptide analogues

(51)⁶ International Patent Classification(s)
C12N 015/11 C07K 014/135

(21) Application No: 199641200 (22) Application Date: 1995.11.07

(87) WIPO No: WO96/14409

(30) Priority Data

(31) Number	(32) Date	(33) Country
94/13307	1994.11.07	FR

(43) Publication Date : 1996.05.31

(43) Publication Journal Date : 1996.07.18

(44) Accepted Journal Date : 1999.04.29

(71) Applicant(s)
Pierre Fabre Medicament

(72) Inventor(s)
Thien Nguyen Ngoc; Hans Binz; Mathias Uhlen; Stefan Stahl; Per Ake Nygren

(74) Agent/Attorney
CARTER SMITH and BEADLE, Qantas House, 2 Railway Parade, CAMBERWELL VIC 3124

(56) Related Art
EP 0249477
WO 87/04728
GB 2188639



<p>(51) Classification internationale des brevets 6 : C12N 15/11, C07K 14/135</p>	<p>A1</p>	<p>(11) Numéro de publication internationale: WO 96/14409 (43) Date de publication internationale: 17 mai 1996 (17.05.96)</p>
<p>(21) Numéro de la demande internationale: PCT/FR95/01464 (22) Date de dépôt international: 7 novembre 1995 (07.11.95) (30) Données relatives à la priorité: 94/13307 7 novembre 1994 (07.11.94) FR (71) Déposant (pour tous les Etats désignés sauf US): PIERRE FABRE MEDICAMENT [FR/FR]; 45, place Abel-Gance, F-92100 Boulogne (FR). (72) Inventeurs; et (75) Inventeurs/Déposants (US seulement): NGUYEN NGOC, Thien [FR/FR]; 7, les Petits Hutin, lathoy, F-74160 Saint-Julien-en-Genevois (FR). BINZ, Hans [CH/FR]; Les Crêtes, F-74160 Beaumont (FR). UHLEN, Mathias [SE/SE]; Surbrunnsgatan 7, S-104 05 Stockholm (SE). STAHL, Stefan [SE/SE]; Torphagsvägen 8, S-104 05 Stockholm (SE). NYGREN, Per, Ake [SE/SE]; Pilotgatan 22, S-128 32 Skarpnack (SE). (74) Mandataire: MARTIN, Jean-Jacques; Cabinet Regimbeau, 26, avenue Kléber, F-75116 Paris (FR).</p>		<p>(81) Etats désignés: AU, CA, JP, NZ, US, brevet européen (AT, BE, CH, DE, DK, ES, FR, GB, GR, IE, IT, LU, MC, NL, PT, SE). Publiée Avec rapport de recherche internationale. Avant l'expiration du délai prévu pour la modification des revendications, sera republiée si de telles modifications sont reçues.</p>

(54) Title: PRODUCTION OF RECOMBINANT PEPTIDES AS NATURAL HYDROPHOBIC PEPTIDE ANALOGUES
 (54) Titre: PRODUCTION DE PEPTIDES RECOMBINANTS, ANALOGUES DE PEPTIDES NATURELS HYDROPHOBES

(57) Abstract

A method for secreting a biologically active recombinant peptide as an analogue of a natural peptide having at least one hydrophobic region, by culturing cells transformed by a nucleic acid construct comprising elements for the expression and secretion of said peptide by the cell, and a sequence coding for a peptide with an amino acid sequence that differs from the natural peptide sequence in that it has at least one modification in a non-transmembrane hydrophobic region of the peptide; and by recovering the peptide and/or cells carrying said recombinant peptide. The resulting recombinant peptide, a corresponding DNA sequence, and a bacterium containing same, are also disclosed.

(57) Abrégé

La présente invention concerne un procédé de sécrétion d'un peptide recombinant biologiquement actif, analogue d'un peptide naturel présentant au moins une région hydrophobe, caractérisé en ce qu'on cultive des cellules transformées par une construction d'acides nucléiques comportant des éléments assurant l'expression et la sécrétion dudit peptide par la cellule, et une séquence codant pour un peptide dont la séquence en acides aminés diffère de la séquence du peptide naturel par au moins une modification dans une région hydrophobe non transmembranaire du peptide, et en ce que l'on récupère le peptide et/ou les cellules portant ledit peptide recombinant. L'invention concerne également un peptide recombinant susceptible d'être ainsi obtenu, une séquence d'ADN correspondante et une bactérie la contenant.

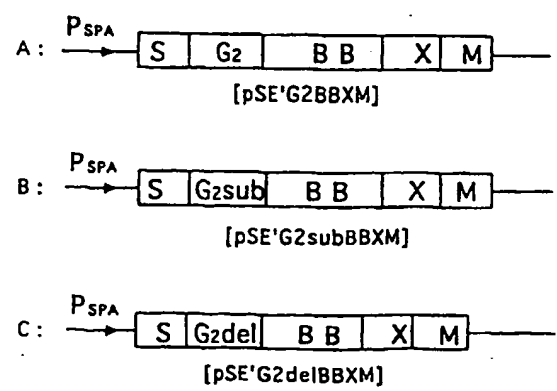
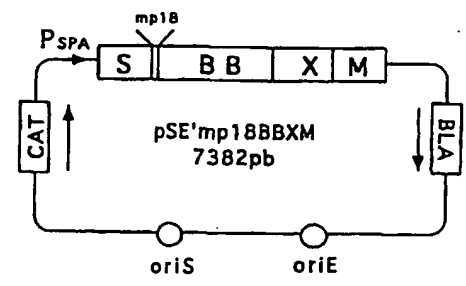

The present invention relates to recombinant peptides which are analogues of natural peptides and which have retained the biological activity of these natural peptides. These peptides can be expressed by different types of cells and their production is improved as compared with that of the natural peptide.

Peptide is understood to mean any substance which is composed of a chain of amino acids, that is an oligopeptide, a polypeptide or a protein.

Peptides possess a wide variety of biological properties and there has been a strong inducement to produce them by genetic manipulation in order, in particular, to avoid the problems of contamination which are associated with the techniques used for purifying them from biological products.

However, the production of peptides by the recombinant route comes up against difficulties associated with the expression system and the host cell. In fact, in order to facilitate their recovery, it is desirable for the peptides to be secreted across the cell membrane in order to obtain them in the extracellular medium or, in the case of Gram-negative bacteria, in the periplasmic space. A system which enables the peptide to be expressed in a form in which it is fused to a membrane anchoring sequence can be introduced into a cell, in particular a bacterium, in such a way as to obtain the fusion product bound covalently to the membrane surface.

For this reason, the applicants have developed, in connection with preparing a vaccine against RSV, a recombinant DNA process which makes it possible to carry out point modifications, by site-directed metagenesis, of the nucleotides in a gene encoding a polypeptide sequence, which process is useful, in particular, for obtaining oral vaccines against respiratory syncytial virus (RSV).

Respiratory syncytial virus (RSV) is the most frequent cause of respiratory diseases in the newborn: bronchopneumopathies (bronchiolites). The WHO estimates that there are 50 million cases of RSV infection



annually, resulting in 160,000 deaths globally. Two subgroups of the virus exist (subgroups A and B).

RSV is classified in the Paramyxoviridae family, genus pneumovirus, and has a non-segmented RNA genome of negative polarity which encodes 10 specific proteins.

Currently, no vaccine against RSV is available. Inactivated virus vaccines have been shown to be ineffective and have sometimes even aggravated the infections of unweaned infants. Attempts in the 1960s to vaccinate with formalin-inactivated RSV led to failure: instead of conferring protection against reinfection with RSV, the vaccine had the effect of exacerbating the disease in infants.

Application WO 87/04185 proposed the use of RSV structural proteins for vaccine purposes, such as the envelope proteins termed protein F (fusion protein) or protein G, a glycoprotein of 22 Kd, a protein of 9.5 Kd or the major capsid protein (protein N).

Application WO 89/02935 describes the protection properties possessed by the entire RSV F protein, where appropriate modified in monomeric or deacetylated form.

A series of fragments of the F protein was cloned with a view to ascertaining their neutralizing properties.

However, the immunizing vaccines which have been tested to date have been found to be ineffective or have induced pulmonary pathology (bronchiolitis or peribronchitis).

At the present moment, there is no basic treatment for infections due to RSV.

RSV infections of the upper airway: treatment is essentially based on symptomatic medication which is identical to that for other viral infections.

RSV infection of the lower airway: in unweaned infants, treatment is based on maintaining correct hydration, aspirating secretions and administering oxygen if required. A positive effect has been observed with ribavirin, a nucleotide which is active against RSV in vitro.



In order to facilitate administration of the vaccine, it would be desirable to have available a product which is active orally, which engenders good immunity and whose side effects are reduced.

The applicants have constructed a novel vector system, also termed a shuttle vector, which functions in *Escherichia coli* and *Staphylococcus xylosum*: the vector encompasses a secretory signal sequence, S, and a membrane anchoring region, XM, which originates from *Staphylococcus aureus* protein A, and has a cloning site between S and XM into which one or more genes can be inserted.

In order to make it easier for the peptide to cross the membrane, the hydrophobicity of the molecule has to be modified in certain cases. Nevertheless, these modifications must not alter the biological, in particular immunogenic, properties of the product.

For this reason, the present invention relates to a process for producing a biologically active recombinant peptide which is an analogue of a natural peptide having at least one hydrophobic region, characterized in that it includes a step in which a DNA construct, which encodes a peptide whose amino acid sequence differs from the sequence of the natural peptide by at least one modification in the said hydrophobic region and which includes elements which ensure that the said peptide is expressed and secreted by the cell, is introduced into a cell, and in that, after the cells have been cultured, the peptide and/or the cells harbouring the said recombinant peptide are recovered.

Accordingly, in one aspect the invention provides a process for secreting a biologically active recombinant peptide which is an analogue of a natural peptide having at least one hydrophobic region, characterized in that it comprises the steps of:

- a) introducing into a cell a DNA construct which includes:
 - elements ensuring expression and secretion of the said peptide by the cell, and
 - a sequence encoding a peptide whose amino acid sequence differs from the sequence of the natural peptide by at least one modification in a non-transmembrane hydrophobic region of the peptide leading to the hydrophobicity reduction of the peptide;
- b) culturing the said cell; and
- c) recovering the said recombinant peptide and/or the cells harbouring the said recombinant peptide.

Preferably, the amino acid sequence is modified at least in one region which is different from the transmembrane region of the natural peptide.



The modification should preferably take place in a region which is not essential for the biological activity of interest of the peptide, which should be preserved.

5 This process makes use of a recombinant DNA construct in which a functional secretory signal sequence

SECRET

SECRET

SECRET



is linked to a structural gene which has been altered in order to modify the structure which allows the recombinant product to cross the membrane of the host cell, whereas the recombinant product of the original structural gene is not allowed to do this when it is linked to the same secretory signal sequence; and the structural modifications of the recombinant product should be carried out by genetic manipulation while altering the location in a host cell of the expressed recombinant product.

According to one aspect of the invention, the modifications are directed towards modifying the hydrophobicity of the recombinant product.

The invention therefore relates to a process for producing recombinant peptide in which the structural modifications of the gene lead to a peptide in which at least one hydrophobic amino acid of the sequence of the natural peptide is replaced by a non-hydrophobic amino acid. In another embodiment, at least one hydrophobic amino acid is, in the recombinant peptide, deleted from the sequence of the natural peptide.

Advantageously, the hydrophobic amino acid is selected from the following group: tryptophan, phenylalanine, proline, valine, alanine, isoleucine, leucine and methionine.

The structural modifications of the gene can be effected by inserting nucleotides or by deleting nucleotides.

Constructs in which the structural modifications of the gene are effected by substituting nucleotides by means of site-directed metagenesis are also included in the invention.

The structural modifications of the gene could be such as to change the location in such a way that the recombinant product is exposed at the membrane surface of the cell by means of a covalent linkage to the membrane anchoring part.

In another embodiment, the structural modifications of the gene can change the location such that the

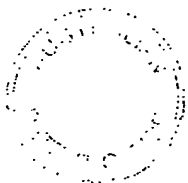

recombinant product is secreted into the culture medium.

The invention also relates, therefore, to the DNA construct which includes a secretory signal sequence which is linked operationally to the DNA sequence which encodes the recombinant peptide and ensures translocation of the said peptide and its secretion outside the cell.

According to another aspect, the invention relates to a process which is characterized in that the DNA construct includes a signal sequence which is linked operationally to the DNA sequence which encodes the said peptide and which allows the peptide to be translocated across the membrane of the host cell and anchored to the membrane.

The invention also relates to recombinant peptides which can be obtained by the process and which are characterized in that they differ from the natural peptide by at least one modification in the hydrophobic region of the natural peptide. They can be anchored to the surface of the host cell. These peptides will be selected, in particular, from among the analogues of an RSV structural protein or of a fragment of such a protein; more especially, the recombinant peptide comprises a sequence which is an analogue of protein G of RSV, subgroup A or B, in particular between residues 130 and 230 of RSV protein G while exhibiting at least 80% homology.

Protein G is an RSV envelope glycoprotein which has a molecular weight of between 84 and 90 Kd and is poor in methionine. The sequence of protein G differs in the A and B subgroups of RSV; when employed in the present application, the term "sequence of protein G" is to be understood to refer at one and the same time to the subgroup A sequence or the subgroup B sequence, when not otherwise specified.

The Applicant has demonstrated that the sequence encompassed between amino acids 130 and 230 of the natural G protein is particularly suitable for inducing effective protection against infection with RSV subgroups A and B without inducing the pathologies which are

observed with vaccines which are based on the whole
formol-inactivated virus or observed with whole F and G
proteins.

5 The means for expressing the polypeptide are
known to the person skilled in the art and are adapted in
accordance with the bacterium employed.

Preferably, the DNA sequence is introduced in the
form of a plasmid, such as a shuttle plasmid.

10 RSV proteins have previously been expressed in
different expression systems such as vaccinia virus,
baculovirus or adenovirus. However, potential problems
are associated with the presence of residual viral
particles.

15 In one of its embodiments, the process according
to the present invention employs a bacterium which is a
commensal of man, is non-pathogenic and is edible. In
particular, the bacterium can belong to the genus
Staphylococcus, i.e. Staphylococcus xylosus which is a
20 bacterium which has been used in the food industry for
many years and can be administered orally in the living
state. Systems for expressing heterologous epitopes at
the surface of S. xylosus have, in particular, been
described by N'guyen et al. in Gene, 1993, 128: 89-94.

25 Preferably, the heterologous polypeptide is
expressed at the surface of the membrane of the bacterium
in a conformation which is essentially identical to that
of the corresponding epitope of the natural protein G.

30 Presentation of the recombinant protein at the
membrane surface of the bacterium depends on its chemical
nature and on its peptide sequence.

The natural sequence of RSV protein G can be used
and a DNA sequence can be introduced which encodes a
peptide which comprises sequence ID No. 1 or sequence ID
No. 2.

35 According to one aspect of the invention, in the
sequence corresponding to the sequence encompassed
between amino acids 130 and 230 of protein G, the amino
acid cysteine in positions 173 and/or 186 has been
replaced by an amino acid which does not form a

disulphide bridge, in particular serine.

Such a mutation promotes formation of the disulphide bridge between the cysteine residues remaining in positions 176 and 182, which bridge is critical for the immunogenicity of the sequence; such a mutation avoids the formation of uncoordinated disulphide bridges.

Peptides which are useful for implementing such a process are, in particular, those which comprise one of the sequences ID No. 3 or ID N. 4.

According to another aspect of the invention, in the sequence of the heterologous polypeptide corresponding to RSV protein G, the phenylalanine amino acids corresponding to positions 163, 165, 168 and/or 170 of the protein G sequence are replaced by a polar amino acid, in particular serine.

This modification can be combined with the previously mentioned mutations. Such a polypeptide can, in particular, exhibit the sequence ID No. 5.

When implementing the process, suppression of the hydrophobic region which is situated upstream of the critical loop formed by the disulphide bridge between the cysteine amino acids in positions 176 and 182 enables the recombinant protein to cross the bacterial membrane more readily and to expose its immunodominant part correctly at the membrane surface.

According to yet another aspect of the invention, the sequence encompassed between amino acids numbered 162 and 170 is deleted in the peptide sequence corresponding to RSV protein G.

More especially, the sequence of the heterologous peptide expressed in the bacterium can comprise the sequence ID No. 6.

The invention also includes a bacterium which expresses a peptide or a protein which can be obtained by the process described in the present application. The said bacterium can be employed in the living or killed state.

Polypeptides or bacteria which exhibit one or more of the above characteristics can be used as

medicaments.

The invention includes pharmaceutical compositions which are characterized in that they comprise a polypeptide or a bacterium according to the invention mixed with acceptable pharmaceutical adjuvants.

The oral vaccine which is based on a living vector should comprise the modified protein which exhibits the optimum conformation for inducing the best protection against RSV.

For this reason, the present invention also relates to application of such a pharmaceutical composition for preparing an oral vaccine which is intended to prevent infections which are caused by respiratory syncytial virus.

Finally, the invention relates to nucleotide sequences which encode a recombinant peptide which is an analogue of a natural peptide such as previously described; these sequences can additionally include elements which ensure expression of the peptide in one or more specific host cells. These elements enable the cells to be targeted in which the construct is to be expressed when it is administered to a human or animal mammal. These sequences can be DNA or RNA constructs which will preferably be incorporated into a vector. Suitable vectors are, in particular, plasmids or viruses of the adenovirus type which it will be possible to formulate into pharmaceutical compositions together with acceptable excipients.

According to one of its aspects, the invention relates to nucleotide sequences which encode a polypeptide which is carried by a peptide sequence encompassed between amino acid residues 130 and 230 of respiratory syncytial virus protein G or which encode a polypeptide exhibiting at least 80% homology with the said peptide sequence, and which also include means for expressing the polypeptide at the surface of the membrane of a non-pathogenic bacterium of the genus *Staphylococcus*.

A DNA sequence which includes

- a functional secretory signal sequence,
- a DNA sequence which encodes a recombinant peptide which is an analogue of a natural peptide, with the recombinant peptide sequence exhibiting at least one modification in the non-transmembrane hydrophobic region of the natural peptide,
5 is part of the invention.

The process according to the invention comprises the following steps:
10

- a. transforming the host cells with a recombinant DNA construct which encompasses a signal sequence which is operationally linked to a structural gene, with this latter being modified such that the recombinant product
15 can be translocated across the membrane of the host cell;
- b. fermenting the said host cell in order to express the recombinant product;
- c. recovering the extracellular proteins which are secreted by the cells which have been transformed
20 with the constructs.

The invention also includes a recombinant cell which harbours a DNA sequence or a construct such as previously defined.

This host cell can be a Gram-positive or Gram-negative bacterium, a yeast cell or a mammalian cell.
25

Particularly suitable bacteria are selected from the group comprising *Escherichia coli*, *Staphylococcus xylosus* and *Staphylococcus carnosus*.

The DNA sequence can be integrated into the chromosome of the gram-positive or gram-negative bacterium.
30

This recombinant DNA construct can encompass the gene which encodes protein G of human RSV subgroup A from amino acid 130 to 230 fused upstream and/or downstream of that of subgroup B.
35

One type of construct can be prepared using the gene which encodes the protein, from amino acid 130 to 230, of bovine RSV which either belongs to subgroup A or to subgroup B.



The following examples are intended to illustrate the invention without limiting its scope in any way.

In these examples, reference will be made to the following figures:

- 5 - Figure 1: Construction of plasmid pRIT28G2 down by gene assembly;
- Figure 2: 1) Construction of gene G2 which is substituted by serine residues;
2) Construction of gene G2 from which residues 162 to 170 have been deleted;
- 10 - Figure 3: Construction of shuttle vector pSE'G2delBBXM;
- Figure 4: Analysis by flow cytometry of the recombinant surface proteins;
- 15 - Figure 5: Analysis by SDS-page of the proteins extracted from the membrane of recombinant *S. xylosus*;
- Figure 6 : scheme of the construction principle of the secreted vectors from the corresponding shuttle vectors pSE'G2subBBXM et pSE'G2delBBXM the description of which are given in example 4. The products secreted from the growing culture medium of *S. xylosus* bearing vectors the stop codon (T) of which having been inserted above the XM membrane anchoring region.
- 20 - Figure 7: Analysis, by SDS page and immunoblot, of the fusion proteins secreted by *S. xylosus*;
- 25 - Figure 8: Analysis by flow cytometry of the proteins secreted by *S. xylosus* harbouring different shuttle vectors.

EXAMPLES

EXAMPLE 1:

- 35 I) Construction of G2 by assembling synthetic genes:

The gene encoding the region encompassing amino acids 130-230 of glycoprotein G of RS virus, termed G2, in which, in comparison to the original sequence, we additionally changed two Cys residues at position 173 and 186 into Ser, is obtained by solid-phase gene assembly techniques (Stahl S. et col., 1993. *BioTechniques*, 14:424-434). The sequence of the oligonucleotides was optimized by combining the common codons of bacteria such as *E. coli* and *Staphylococcus*.

The oligonucleotides were synthesized by phosphoramidite chemistry on an automated DNA synthesizer (Gene Assembler Plus, Pharmacia Biotech) according to the manufacturer's recommendations. The oligonucleotides to be bound to the solid phase are biotinylated at the 5' end with the reagent Biotin-on phosphoramidite (Clontech). The other oligonucleotides are phosphorylated at the 5' end with the reagent Phosphate-on amidite (Clontech) according to the Clontech protocol. The oligonucleotides are deprotected and are purified in accordance with Pharmacia's recommendations. The biotinylated oligonucleotides are purified by reverse phase liquid chromatography (PEP RPC column:, Pharmacia).

The gene is assembled in two parts: G2up (upstream), from amino acid 130 to 177 with two restriction sites, BamHI and PstI, 5' and 3' of the gene, G2down (downstream), from amino acid 177 to 230 with two restriction sites, PstI and BamHI, 5' and 3' of the gene. The G2 gene is reconstituted by ligating the two fragments G2up and G2down by means of the PstI site.

a) Assembling the G2up gene (FIGURE 1):

In a micro tube, two complementary oligonucleotides, one of which is 5'-biotinylated: TH1B = 5'-biotin-CCGGATCCT ATGACCGTGA A-3' and TH2 = 5'-GTTTTTGGTT TTCACGGTCA TAGGATCCGG-3', are hybridized and immobilized on magnetic beads which are coupled to streptavidin (Dynal, Oslo, Norway). The immobilized double strand includes a BamHI restriction site, and the strand which is complementary to the biotinylated strand possesses an overhang of from 6 to 15 nucleotides at its 5' end (phosphorylated) to which the following oligonucleotide can hybridize. Hybridization of this latter oligonucleotide is carried out while raising the temperature of the medium to 70°C in order to avoid formation of secondary structures. Ligation is accomplished by adding T4 DNA ligase (Gibco BRL). The gene is constructed successively in this manner while taking the precaution, in each cycle, of rinsing the solid support in order to eliminate

excess non-bound oligonucleotides before adding the following oligonucleotide. The last double strand to be ligated on contains a PstI restriction site.

5 The double strand is then released from its solid support by digesting it with restriction enzymes BamHI and PstI and then ligated into the cloning and sequencing vector pRIT28 (Hultman et al., 1988, Nucleosides Nucleotides 7:629-638) which has been digested with the same enzymes: the resulting vector is pRIT28G2up, which is 10 3067bp in size. The nucleotide sequence of G2up is determined by DNA sequencing on an automated ABI sequencer in accordance with the manufacturer's recommendations (Applied Biosystems).

b) Assembling the G2down gene (FIGURE 1):

15 In the same way, the G2down gene is solid-phase assembled on magnetic beads with the two first complementary oligonucleotides, one of which is 5'-biotinylated, : TH13B = (5'-biotin-TGTGAAGCTT AGTCGACCGG TTTG-3') and TH12 = (5'-GCCGACCACC AAACCGGTCG ACTAAGCTTC ACA-3'), and 20 so on. The double strand is released from the solid support by successive enzymic digestion with PstI and HindIII and cloned into pRIT28: the resulting vector is termed pRIT28G2down and is 3091bp in size. The nucleotide sequence of G2down is determined by DNA 25 sequencing on an automated ABI sequencer in accordance with the manufacturer's (Applied Biosystems) recommendations.

c) Construction of the G2 gene = G2up + G2down:

30 The two fragments, G2up and G2down, are ligated by means of the PstI restriction site, and the gene which has been formed is cloned into pRIT28 using the 5'BamHI site and 3' HindIII site: the resulting vector is termed pRIT28G2 and is 3220bp in size. The nucleotide sequence of G2 is determined by DNA sequencing on an automated ABI 35 sequencer in accordance with the manufacturer's (Applied Biosystems) recommendations. The G2 fragment is digested with BamHI and HindIII and cloned into shuttle vector:

pSE'G2BBXM (7666bp) (FIGURE 3).

List of oligonucleotides which are required for assembling the G2 genes:

BamHI

TH1B (20mer): 5'-Biotin-CCGGATCCT ATGACCGTGA A-3'

BamHI

TH2 (30mer): 5'-GTTTTTGGTT TTCACGGTCA TAGGATCCGG-3'

TH3 (28mer): 5'-AACCAAAAAC ACCACGACCA CCCAGACC-3'

TH4 (31mer): 5'-GTTTGCTCGG CTGGGTCTGG GTGGTCGTGG T-3'

TH5 (31mer): 5'-CAGCCGAGCA AACCGACCAC CAAACAGCGTC-3'

TH6 (29mer): 5'-CGGTTTGTTG TGACGCTGTT TGGTGGTCG-3'

TH7 (29mer): 5'-AGAACAAACC GCCGAACAAA CCGAACAAAC-3'

TH8 (34mer): 5'-CTTCGAAATG GAAATCGTTG TTCGGTTTGT TCGG-3'

TH9 (27mer): 5'-GATTTCATT TCGAAGTGT CAACTTC-3'

Pst I

TH10 (33mer): 5'-TGCTGCAGAT GCTGCTCGGC ACGAAGTTGA ACA-3'

Pst I

TH11 (22mer): 5'-GTGCCGAGCA GCATCTGCAG CA-3'

HindIII

TH12 (33mer): 5'-GCCGACCACC AAACCGGTCC ACTAAAGCTTC ACA-3'

HindIII

TH13B (19mer): 5'-Biotin-CCCTGTGAAAG CTTGGTTTG-3'

TH14 (32mer): 5'-CATAAACCGC AGACCACCAA ACCGAAAGAA GT-3'

TH15 (32mer): 5'-GTGGTCCGCA CTCTTTCCGG TTGGTGGTC TG-3'

TH16 (31mer): 5'-AAAACCGACC TTCAAACCA CCAAAAAAGA T-3'

TH17 (31mer): 5'-CGGTTTATGA TCTTTTTTGG TGGTTTTGAA G-3'

TH18(30mer): 5'-GGGCAAAAA ACCACGACCA AACCGACCAA-3'

TH19 (31mer): 5'-GTCGGTTTT TGGTCGGTTT GGTCTGGTT T-3'

TH20 (34mer): 5'-GGGCGATCAG CAAACGTATC CCGAACAAAA AACCG-3'

TH21 (33mer): 5'-TTTTGCCCG TTTTTGTTC GGGATACGTT TGC-3'

Pst I

TH22(25mer): 5'-ATC TGCAGCAACA ACCCGACCTG CT-3'

Pst I

TH23 (34mer): 5'-TGATCGCCCA GCAGTCCGG TTGTTGCTGC AGAT-3'

5 II) Construction of G2sub by means of site-directed mutagenesis:

The gene fragment in which the four phenylalanine residues in positions 163, 165, 168 and 170 are replaced with serines is generated, by gene amplification (PCR), from the G2 gene which is inserted into the vector pRIT28

using RIT27/TNG73 and RIT28/TNG72 as primer pairs (see FIGURE 2. (1)). The primers TNG72 and TNG73 are complementary to a region of 19 nucleotides which encompasses three of the four phenylalanines:

5 RIT27: 5'-GCTTCCGGCT CGTATGTTGT GTG-3'
RIT28: 5'-AAAGGGGGAT GTGCTGCAAG GCG-3'
TNG72 5'-C CAT TCC GAA GTG TCC AAC TCC GTG CCG AGC AG-3'
TNG73 3'-GC TTG CTA AGG GTA AGG CTT CAC AGG TTG-5'

On the one hand, primer TNG73 introduces the
10 first three mutations (TTC to TCC) in the upstream
fragment which is amplified together with RIT27. On the
other hand, primer TNG72 introduces the last three
mutations (TTC to TCC) into the downstream fragment which
is amplified together with RIT28. Five cycles of tempera-
15 tures (96°C, 15 sec; 50°C, 1 min; 72°C, 1 min) are
followed by five cycles of (96°C, 15 sec; 60°C, 15 sec;
72°C, 15 sec). The two amplified fragments are mixed in
a single tube and diluted in PCR buffer without primers,
and the extension reaction is carried out in five cycles
20 using the following temperatures (96°C, 15 sec; 54°C, 30
sec; 72°C, 1 min). The extension product is diluted 1/100
in PCR buffer containing the RIT27 and RIT28 primers and
gene amplification is carried out for 30 cycles at the
following temperatures (96°C, 15 sec; 54°C, 15 sec; 72°C,
25 30 sec). The fragment is then digested with restriction
enzymes BamHI/HindIII and cloned into vector pRIT28 which
has been digested with the same enzymes, giving:
pRIT28G2sub. The nucleotide sequence of G2sub is deter-
mined by DNA sequencing on an ABI automated sequencing
30 appliance in accordance with the manufacturer's (Applied
Biosystems) recommendations. The G2sub fragment is
digested with BamHI and HindIII and cloned into shuttle
vector pSE'G2subBBXM (7666bp) (FIGURE 3).

III) Construction of G2del: (see FIGURE 2.(2))

35 In the same way, the G2 gene fragment from which
the part encompassing the 4 phenylalanine residues, from
amino acid 162 to amino acid 170, has been deleted is
generated by PCR in the form of two fragments: upstream

using primers RIT27/TH48 on the one hand and downstream using RIT28/TH11 on the other. The primers TH11 and TH48 are complementary to each other over 13 nucleotides.

TH11 5'-GTGCCGAGCA GCATCTGCAG CA-3'
5 3'-GGCTTGTTT GGCTTGTTG CACGGCTCGT CGT-5' = TH48

Five cycles of the following temperatures (96°C, 15 sec; 52°C, 1 min; 72°C, 1 min) are followed by twenty cycles of the following temperatures (96°C, 15 sec; 60°C, 15 sec; 72°C, 15 sec). The two amplified fragments are
10 mixed in a single tube and diluted in PCR buffer without primer, and the extension reaction is carried out in five cycles of the following temperatures (96°C, 15 sec; 42°C, 30 sec; 72°C, 1 min). The extension product is diluted 1/100 in PCR buffer containing the RIT27 and RIT28
15 primers, and gene amplification is effected in 30 cycles of the following temperatures (96°C, 15 sec; 60°C, 15 sec; 72°C, 30 sec). The fragment is then digested with restriction enzymes BamHI/HindIII and cloned into vector pRIT28 which has been digested with the same enzymes,
20 giving pRIT28G2del. The nucleotide sequence of G2del is determined by DNA sequencing on an automated ABI sequencing appliance in accordance with the manufacturer's (Applied Biosystems) recommendations. The G2del fragment is digested with BamHI and HindIII and cloned into
25 shuttle vector pSE'G2delBBXM (7639bp) (FIGURE 3).

IV) Construction of the shuttle vector:

An oligonucleotide linker (5'-AGCTTGGCTG TTCCGCCATG GCTCGAG-3', together with the complementary
30 strand) is inserted into the HindIII site of the plasmid pSZZmp18XM (Hansson et al., 1992, J. Bacteriol 174: 4239-4245), thereby creating two additional restriction sites, NcoI and XhoI, downstream of the HindIII site of the resulting vector pSZZmp18(XhoI)XM. A gene fragment encoding 198 amino acids, termed BB, from the serum albumin binding region of streptococcal protein G (Nygren et al., 1988, J.Mol.Reconig., 1:69-74), is generated by
35

PCR, using primers (1 = 5'-CCGAATTCAA GCTTAGATGC TCTAGCA-
AAA GCCAAG-3' and 2 = 5'-CCCCTGCAGT TAGGATCCCT CGAGAGGTAA
TGCAGCTAAA ATTCATC-3'), on a template consisting of
plasmid pSPG1 (Guss et al., 1986, EMBO J., 5: 1567-1575).

5 The fragment is digested with HindIII and XhoI and cloned
downstream of the mp18 multiple cloning site of vector
pSZZmp18(XhoI)XM; the resulting vector,
pSZZmp18(XhoI)BBXM, is digested with NotI and HindIII.
The fragment encompassing ZZ is replaced with another
10 fragment, which has been digested with the same
restriction enzymes, from vector pE'mp18 (Sophia Hober,
unpublished). The resulting shuttle vector is termed
pSE'mp18BBXM (FIGURE 3).

EXAMPLE 2:

15 Extraction and analysis of the membrane proteins from
recombinant *S. xylosus* strains:

250 ml of medium (7.5 g of TSB, 12.5 g of yeast
extract) containing chloramphenicol (20 µg/ml), together
with 5 ml of an overnight preliminary culture of
20 *S. xylosus* which has been transformed with one of the
shuttle vectors pSE'G2BBXM, pSE'G2subBBXM or
pSE'G2delBBXM in accordance with the protocol of Götz et
al., 1981, J Bacteriol., 145:74-81, are inoculated into
a 1 litre Erlenmeyer flask. The flask is incubated at a
25 temperature of 32°C for 6 hours with shaking. The medium
is centrifuged at 5000 rpm for 12 min at a temperature of
4°C. The bacterial pellet is resuspended in 40 ml of TST,
and 200 µl of a solution containing lysostaphin (1 mg/ml)
are added, followed by 200 µl of lysozyme (50 mg/ml). The
30 mixture is incubated at a temperature of 37°C for one
hour with gentle shaking. The solution is then sonicated
for 2 min using a Vibra cell appliance which is equipped
with a probe whose power is adjusted to 7. The mixture is
centrifuged at 13,500 rpm for 20 min at a temperature of
35 4°C. The proteins are affinity-purified: the supernatant
is passed through an HSA-Sepharose (human serum albumin)
affinity column. After the column has been rinsed, the
proteins are eluted with an acid buffer, pH 2.7, and

lyophilized.

The proteins are separated on two identical 12% SDS-PAGE gels using prestained standard molecular weight markers (Gibco BRL). One gel is stained with Coomassie blue. The second is transferred to a Problot™ (Applied Biosystem) membrane for immunoblotting with anti-G1 specific antibody (obtained from the serum of a rabbit immunized with G1(aal74-187) peptide in accordance with current immunization protocols). See Figure 5.

10 EXAMPLE 3:

Flow cytometry (FACScan™) analysis of the recombinant proteins at the surface of S. xylosus:

Cultures of recombinant S. xylosus bacteria are prepared as previously described. In order to make a stock solution, the bacterium is resuspended in a solution of PBS containing 0.1% (w/v) sodium azide at a final concentration of unity as determined by optical density (600 nm). 30 µl of stock solution are aliquoted into each conical well of a microtitre plate, which is centrifuged at 550 g for 10 minutes at 4°C. The bacterial pellet is resuspended in a volume of 150 µl of PBS solution containing 200-times diluted anti-G2 polyclonal rabbit serum (titred 1/1 280 000), and the mixture is incubated for 30 minutes. The bacterial cells are rinsed twice with PBS and incubated in 150 µl of a PBS solution containing 100-times diluted FITC anti-rabbit (Sigma) for 30 minutes. After the cells have been rinsed twice with PBS buffer, they are resuspended in a Falcon tube containing 1 ml of 1% (w/v) PBS-paraformaldehyde buffer. The samples which have thus been prepared are analysed in a FACScan™ (Becton Dickinson) apparatus. The fluorescence distribution of each cell suspension is analysed using LYSIS II™ software and is depicted by the fluorescence histograms. See Figure 4.

35 EXAMPLE 4:

Modulation from secretion/insertion to secretion:

Using different shuttle vectors, it is possible

to insert termination codons upstream of the membrane anchorage-encoding region, XM, as shown in Figure 6. A unique XhoI restriction site between BB and XM was used to insert a double-stranded oligonucleotide which encodes
5 three termination codons (Ter) in both orientations, while introducing an Aat II restriction site:

AatII Ter Ter Ter -->
5'-TC GAC GTC TAA TGA TAA TTA TCA TTA G-3'
3'-G CAG ATT ACT ATT AAT AGT AAT CAG CT-5'
<- Ter Ter Ter

Thus, vectors pSE'G2subBBXM and pSE'G2delBBXM are digested with Xho I and ligated to the double-stranded oligonucleotide, which has previously been 5' phosphorylated. The resulting vectors are, respectively,
10 pSE'G2subBB[Ter]XM (7693bp) and pSE'G2delBB[Ter]Xm (7666bp). Proteins G2subBB and G2delBB can be obtained by culturing *E. coli* or *S. xylosus* cells which have been transformed, respectively, with these two vectors and
15 then purifying on an affinity column (HSA-sepharose). Figure 7 shows: in A) the SDS-PAGE gel; separation, under reducing conditions, of the proteins secreted from *S. xylosus*, with 1 and 2 representing proteins G2subBB and G2delBB, respectively, of the expected sizes:
20 35.23 Kda and 34.28 Kda; in B) the immunoblot of the proteins demonstrates that the antibody which is specific for the G(aa174-187) region or G1 of RSV readily recognizes the two secreted proteins. Very little proteolytic degradation was observed. In addition,
25 FACSCAN analysis was carried out on the different *S. xylosus* strains using rabbit anti-BB polyclonal antibody. Figure 8 shows that the spectra for *S. xylosus* harbouring shuttle vectors pSE'mpl8BBXM, pSE'G2subBBXM and pSE'G2delBBXM are displaced in their axis of
30 fluorescence intensity towards the right, that is towards the presence of heterologous antigens at the bacterial surface. By contrast, the spectra for *S. xylosus* harbouring shuttle vectors pSE'G2subBBTerXM and pSE'G2delBBTerXM

are not displaced, indicating that heterologous antigens are absent from the bacterial surface and that they were found in, and purified from, the culture medium.

SEQUENCE LISTING

(1) GENERAL INFORMATION:

(i) APPLICANT:

- (A) NAME: PIERRE FABRE MEDICAMENT
- (B) STREET: 45, PLACE ABEL GANCE
- (C) CITY: BOULOGNE
- (E) COUNTRY: FRANCE
- (F) POSTAL CODE (ZIP): 92100

(ii) TITLE OF INVENTION: PRODUCTION OF PEPTIDES WHICH ARE ANALOGUES OF HYDROPHOBIC PEPTIDES , RECOMBINANT PEPTIDE, CORRESPONDING DNA SEQUENCE

(iii) NUMBER OF SEQUENCES: 6

(iv) COMPUTER READABLE FORM:

- (A) MEDIUM TYPE: Floppy disk
- (B) COMPUTER: IBM PC compatible
- (C) OPERATING SYSTEM: PC-DOS/MS-DOS
- (D) SOFTWARE: PatentIn Release #1.0, Version #1.30 (EPO)

(vi) PRIOR APPLICATION DATA :

- (A) APPLICATION NUMBER : FR 9413307
- (B) FILING DATE : 07-NOV-1994

(2) INFORMATION FOR SEQ ID NO: 1:

(i) SEQUENCE CHARACTERISTICS:

- (A) LENGTH: 303 base pairs
- (B) TYPE: nucleic acid
- (C) STRANDEDNESS: single
- (D) TOPOLOGY: linear

(ii) MOLECULE TYPE: DNA

(ix) FEATURE :

- (A) NAME/KEY : CDS
- (B) LOCATION : 1..303

SEQUENCE LIST

INFORMATION-FOR SEQ ID NO:1

5 TYPE = amino acids and nucleotides
LENGTH = 101 amino acids, 303 nucleotides
STRANDEDNESS = single
TOPOLOGY = linear

MOLECULE TYPE = protein

130

N -Thr Val Lys Thr Lys Asn Thr Thr Thr Thr Gln Thr Gln
5'-ACC GTG AAA ACC AAA AAC ACC ACG ACC ACC CAG ACC CAG

143

Pro Ser Lys Pro Thr Thr Lys Gln Arg Gln Asn Lys Pro Pro Asn Lys Pro Asn
CCG AGC AAA CCG ACC ACC AAA CAG CGT CAG AAC AAA CCG CCG AAC AAA CCG AAC

161

Asn Asp Phe His Phe Glu Val Phe Asn Phe Val Pro Cys Ser Ile Cys Ser Asn
AAC GAT TTC CAT TTC GAA GTG TTC AAC TTC GTG CCG TGC AGC ATC TGC AGC AAC

174

179

Asn Pro Thr Cys Trp Ala Ile Cys Lys Arg Ile Pro Asn Lys Lys Pro Gly Lys
AAC CCG ACC TGC TGG GCG ATC TGC AAA CGT ATC CCG AAC AAA AAA CCG GGC AAA

187

197

Lys Thr Thr Thr Lys Pro Thr Lys Lys Pro Thr Phe Lys Thr Thr Lys Lys Asp
AAA ACC ACG ACC AAA CCG ACC AAA AAA CCG ACC TTC AAA ACC ACC AAA AAA GAT

215

His Lys Pro Gln Thr Thr Lys Pro Lys Glu Val Pro Thr Thr Lys Pro - C Ter
CAT AAA CCG CAG ACC ACC AAA CCG AAA GAA GTG CCG ACC ACC AAA CCA - 3'

230

INFORMATION FOR SEQ ID NO:2

TYPE = amino acids and nucleotides

LENGTH = 101 amino acids, 303 nucleotides

STRANDEDNESS = single

5 TOPOLOGY = linear

MOLECULE TYPE = protein

130

-Thr Ala Gln Thr Lys Gly Arg Ile Thr Thr Ser Thr Gln

5' -ACC GCG CAG ACC AAA GGC CGT ATC ACC ACC AGC ACC CAG

143

Thr Asn Lys Pro Ser Thr Lys Ser Arg Ser Lys Asn Pro Pro Lys Lys Pro Lys
ACC AAC AAA CCG AGC ACC AAA AGC CGT AGC AAA AAC CCG CCG AAA AAA CCG AAA

161

Asp Asp Tyr His Phe Glu Val Phe Asn Phe Val Pro Cys Ser Ile Cys Gly Asn
GAT GAT TAC CAC TTC GAA GTG TTC AAC TTC GTG CCC TGC AGC ATC TGC GGC AAC

174

179

187

Asn Gln Leu Cys Lys Ser Ile Cys Lys Thr Ile Pro Ser Asn Lys Pro Lys Lys
AAC CAG CTG TGC AAA AGC ATC TGC AAA ACC ATC CCG AGC AAC AAA CCG AAA AAG

197

Lys Pro Thr Ile Lys Pro Thr Asn Lys Pro Thr Thr Lys Thr Thr Asn Lys Arg
AAA CCG ACC ATC AAA CCG ACC AAC AAA CCG ACC ACC AAA ACC ACC AAC AAA CGT

215

230

Asp Pro Lys Thr Pro Ala Lys Met Pro Lys Lys Glu Ile Ile Thr Asn - C Ter
GAT CCG AAA ACC CCG GCG AAA ATG CCG AAG AAG GAA ATC ATC ACC AAC - 3'

INFORMATION FOR SEQ ID NO:3

TYPE = amino acids and nucleotides
LENGTH = 101 amino acids, 303 nucleotides
STRANDEDNESS = single
5 TOPOLOGY = linear

MOLECULE TYPE = protein

130

-Thr Val Lys Thr Lys Asn Thr Thr Thr Thr Gln Thr Gln
5'-ACC GTG AAA ACC AAA AAC ACC ACG ACC ACC CAG ACC CAG

143

Pro Ser Lys Pro Thr Thr Lys Gln Arg Gln Asn Lys Pro Pro Asn Lys Pro Asn
CCG AGC AAA CCG ACC ACC AAA CAG CGT CAG AAC AAA CCG CCG AAC AAA CCG AAC

161

Asn Asp Phe His Phe Glu Val Phe Asn Phe Val Pro Ser Ser Ile Cys Ser Asn
AAC GAT TTC CAT TTC GAA GTG TTC AAC TTC GTG CCG AGC AGC ATC TGC AGC AAC

174

179

Asn Pro Thr Cys Trp Ala Ile Ser Lys Arg Ile Pro Asn Lys Lys Pro Gly Lys
AAC CCG ACC TGC TGG GCG ATC AGC AAA CGT ATC CCG AAC AAA AAA CCG GGC AAA

187

197

Lys Thr Thr Thr Lys Pro Thr Lys Lys Pro Thr Phe Lys Thr Thr Lys Lys Asp
AAA ACC ACG ACC AAA CCG ACC AAA AAA CCG ACC TTC AAA ACC ACC AAA AAA GAT

215

His Lys Pro Gln Thr Thr Lys Pro Lys Glu Val Pro Thr Thr Lys Pro - C Ter
CAT AAA CCG CAG ACC ACC AAA CCG AAA GAA GTG CCG ACC ACC AAA CCA - 3'

230

INFORMATION FOR SEQ ID NO:4

TYPE = amine acids and nucleotides
LENGTH = 101 amino acids, 303 nucleotides
STRANDEDNESS = single
5 TOPOLOGY = linear

MOLECULE TYPE = protein

130

N -Thr Ala Gln Thr Lys Gly Arg Ile Thr Thr Ser Thr Gln
5'-ACC GCG CAG ACC AAA GGC CGT ATC ACC ACC AGC ACC CAG

143

Thr Asn Lys Pro Ser Thr Lys Ser Arg Ser Lys Asn Pro Pro Lys Lys Pro Lys
ACC AAC AAA CCG AGC ACC AAA AGC CGT AGC AAA AAC CCG CCG AAA AAA CCG AAA

161

Asp Asp Tyr His Phe Glu Val Phe Asn Phe Val Pro Ser Ser Ile Cys Gly Asn
GAT GAT TAC CAC TTC GAA GTG TTC AAC TTC GTG CCC AGC AGC ATC TGC GGC AAC

174

179

Asn Gln Leu Cys Lys Ser Ile Ser Lys Thr Ile Pro Ser Asn Lys Pro Lys Lys
AAC CAG CTG TGC AAA AGC ATC AGC AAA ACC ATC CCG AGC AAC AAA CCG AAA AAG

187

197

Lys Pro Thr Ile Lys Pro Thr Asn Lys Pro Thr Thr Lys Thr Thr Asn Lys Arg
AAA CCG ACC ATC AAA CCG ACC AAC AAA CCG ACC ACC AAA ACC ACC AAC AAA CGT

215

Asp Pro Lys Thr Pro Ala Lys Met Pro Lys Lys Glu Ile Ile Thr Asn - C Ter
GAT CCG AAA ACC CCG GCG AAA ATG CCG AAG AAG GAA ATC ATC ACC AAC - 3'

230

INFORMATION FOR SEQ ID NO:5

TYPE = amino acids
LENGTH = 30 amino acids
STRANDEDNESS = single
5 TOPOLOGY = linear

MOLECULE TYPE = protein

160 162 163 165 168 170 173
Asn Asn Asp Ser His Ser Glu Val Ser Asn Ser Val Pro Ser Ser
175 176 182 186
Ile Cys Ser Asn Asn Pro Thr Cys Trp Ala Ile Ser Lys Arg Ile

INFORMATION FOR SEQ ID NO:6

TYPE = amino acids and nucleotides
LENGTH = 30 amino acids
STRANDEDNESS = single
5 TOPOLOGY = linear

MOLECULE TYPE = protein

160
Asn Asn Val Pro Ser Ser Ile Cys Ser Asn Asn Pro Thr Cys Trp
175
Ala Ile Ser Lys Arg Ile Pro Asn Lys Lys Pro Gly Lys Lys Thr

FIGURE LEGENDS

Figure 5: A) Staining with Comassie blue: SDS Page gel of
fusion proteins which were extracted from the membranes
10 of bacteria harbouring different constructs and purified
on an albumin affinity column:

- Well HW: Molecular size markers (in Kda).
- well 1: S. xylosus [pSE'G2BBXM].
- well 2: S. xylosus [pSE'G2subBBXM].
- 15 - well 3: S. xylosus [pSE'G2delBBXM].

B) Immunoblot, obtained with rabbit anti-G1 polyclonal
antibody, of the fusion proteins which were extracted
from the membranes of bacteria harbouring different
constructs and purified on an albumin affinity column.

- 20 - Well HW: Prestained molecular size markers (in Kda).
- well 1: S. xylosus [pSE'G2BBXM].
- well 2: S. xylosus [pSE'G2subBBXM].
- well 3: S. xylosus [pSE'G2delBBXM].

Figure 7: A) Staining with Comassie blue: SDS-page gel of
25 fusion proteins which were secreted from bacteria
harbouring different constructs and purified on an
albumin affinity column:

- well 1: S. xylosus [pSE'G2delBB] (34.28 Kda).
- well 2: S. xylosus [pSE'G2subBB] (35.23 Kda).
- 30 - well HW: Molecular size markers (in Kda).

B) Immunoblot, obtained with rabbit anti-G1 (RSV) polyclonal antibody, of the fusion proteins which were secreted from bacteria harbouring different constructs and purified on an albumin affinity column.

- 5
- well 1: *S. xylosus* [pSE'G2delBB] (34.28 Kda).
 - well 2: *S. xylosus* [pSE'G2subBB] (35.23 Kda).
 - well HW: Prestained molecular size markers (in Kda).

The claims defining the invention are as follows:

1. Process for secreting a biologically active recombinant peptide which is an analogue of a natural peptide having at least one hydrophobic region, characterized in that it comprises the steps of:

- 5 a) introducing into a cell a DNA construct which includes:
- elements ensuring expression and secretion of the said peptide by the cell, and
 - a sequence encoding a peptide whose amino acid sequence differs from the sequence of the natural peptide by at least one modification in a non-transmembrane hydrophobic region of the peptide leading to the hydrophobicity reduction of the peptide;
- 10 b) culturing the said cell; and
- c) recovering the said recombinant peptide and/or the cells harbouring the said recombinant peptide.

15 2. Process according to Claim 1, characterized in that at least one hydrophobic amino acid of the sequence of the natural peptide is replaced by a non-hydrophobic amino acid.

20 3. Process according to one of Claims 1 and 2, characterized in that at least one hydrophobic amino acid is deleted from the sequence of the natural peptide.

4. Process according to one of Claims 1 to 3, characterized in that the hydrophobic amino acid is selected from the following group: tryptophan, phenylalanine, proline, valine, alanine, isoleucine, leucine and methionine.

25 5. Process according to one of Claims 1 to 4, characterized in that the DNA construct includes a secretory signal sequence which is linked operationally to the DNA sequence which encodes the recombinant peptide and ensures translocation of the said peptide and its secretion outside the cell.

30 6. Process according to one of Claims 1 to 4, characterized in that the DNA construct includes a signal sequence which is linked operationally to the DNA sequence which encodes the said peptide and which allows the peptide to be translocated across the membrane of the host cell and anchored to the membrane.

7. Recombinant peptide which can be obtained by the



process according to one of Claims 1 to 6, characterized in that it differs from the natural peptide by at least one modification in the hydrophobic region of the natural peptide.

- 5 8. Recombinant peptide according to Claim 7, characterized in that it is anchored to the surface of the host cell.
9. Recombinant peptide according to one of Claims 7 or 8, characterized in that it is an analogue of an RSV structural protein or of a fragment of such a protein.
- 10 10. Recombinant peptide according to one of Claims 7 to 9, characterized in that it comprises a sequence which is an analogue of protein G of RSV, subgroup A or B.
11. Recombinant peptide according to one of Claims 7 to 10, characterized in that it comprises a sequence which is an analogue of the sequence encompassed between residues 130 and 230 of RSV protein G.
- 15 12. Recombinant peptide according to one of Claims 7 to 11, characterized in that it exhibits one of the sequences ID No. 1, No. 2, No. 3, No. 4, No. 5 or No. 6.
- 20 13. Nucleotide sequence which encodes a peptide according to one of Claims 7 to 12.
14. Nucleotide sequence according to Claim 13, characterized in that it additionally includes elements which ensure expression of the peptide in one or more specific host cells.
- 25 15. Nucleotide sequence according to one of Claims 13 or 14, characterized in that it is a DNA sequence.
16. Nucleotide sequence according to one of Claims 13 or 14, characterized in that it is an RNA sequence.
- 30 17. Expression vector, characterized in that it includes a nucleotide sequence according to one of Claims 13 to 16.
18. Pharmaceutical composition which is intended to be administered to a mammal in order to bring about the in-situ production of a peptide, characterized in that it contains an expression vector according to Claim 17.
- 35 19. DNA sequence which can be used in the process according to one of Claims 1 to 6, characterized in that

it includes:

- a functional secretory signal sequence,
 - a DNA sequence which encodes a recombinant peptide which is an analogue of a natural peptide, with the recombinant peptide sequence exhibiting at least one modification in a non-transmembrane hydrophobic region of the natural peptide.
- 5
20. Recombinant cell, characterized in that it harbours a DNA sequence according to one of Claims 15 and 16 or 19.
- 10
21. Cell according to Claim 20, characterized in that it is a gram-negative bacteria.
22. Cell according to Claim 20, characterized in that it is a gram-positive bacteria.
23. Cell according to Claim 20, characterized in that it is a yeast cell.
- 15
24. Cell according to Claim 20, characterized in that it is a mammalian cell.
25. Bacterium according to one of Claims 22 or 23, characterized in that it is selected from *Escherichia coli*, *Staphylococcus xylosus*, *Staphylococcus carnosus*.
- 20
26. Gram-negative bacterium according to Claim 21, characterized in that the recombinant DNA sequence is integrated into the chromosome of the host.
27. Gram-positive bacterium according to Claim 22, characterized in that it harbours a recombinant DNA sequence which is integrated into the chromosome of the host.
- 25
28. Pharmaceutical composition, characterized in that it contains a cell according to one of Claims 20 to 27.
29. A process according to any one of Claims 1 to 6 substantially as hereinbefore described.
- 30
30. Recombinant peptide according to any one of claims 7 to 12 substantially as hereinbefore described.
31. An expression vector according to claim 17 substantially as hereinbefore described.



32. A pharmaceutical composition according to claim 18 or 28 substantially as hereinbefore described.

33. A cell according to any one of claims 20 to 24 substantially as
5 hereinbefore described.

34. A bacterium according to any one of claims 25 to 27 substantially as hereinbefore described.

DATED: 26 February 1999

CARTER SMITH & BEADLE
Patent Attorneys for the Applicants:

PIERRE FABRE MEDICAMENT



MAW:PP:#25211.RS1

26 February 1999

PATENT

PRODUCTION OF PEPTIDES WHICH ARE ANALOGUES OF HYDROPHOBIC PEPTIDES, RECOMBINANT PEPTIDE, CORRESPONDING DNA SEQUENCE

Applicant: PIERRE FABRE MEDICAMENT

ABSTRACT

The present invention relates to a process for secreting a biologically active recombinant peptide which is an analogue of a natural peptide having at least one hydrophobic region, characterized in that cells which are transformed with a nucleic acid construct which includes

- elements ensuring expression and secretion of the said peptide by the cell, and
- a sequence encoding a peptide whose amino acid sequence differs from the sequence of the natural peptide by at least one modification in a non-transmembrane hydrophobic region of the peptide,

are cultured and in that the peptide and/or the cells harbouring the said recombinant peptide are recovered.

The invention also relates to a recombinant peptide which can be obtained in this manner, to a corresponding DNA sequence and to a bacterium which harbours it.

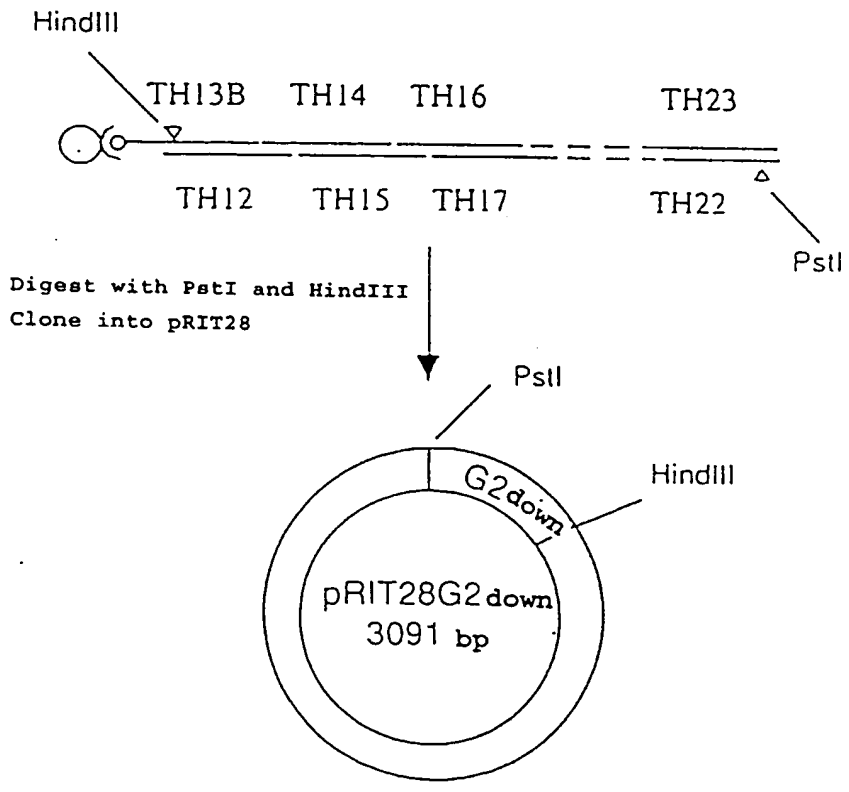
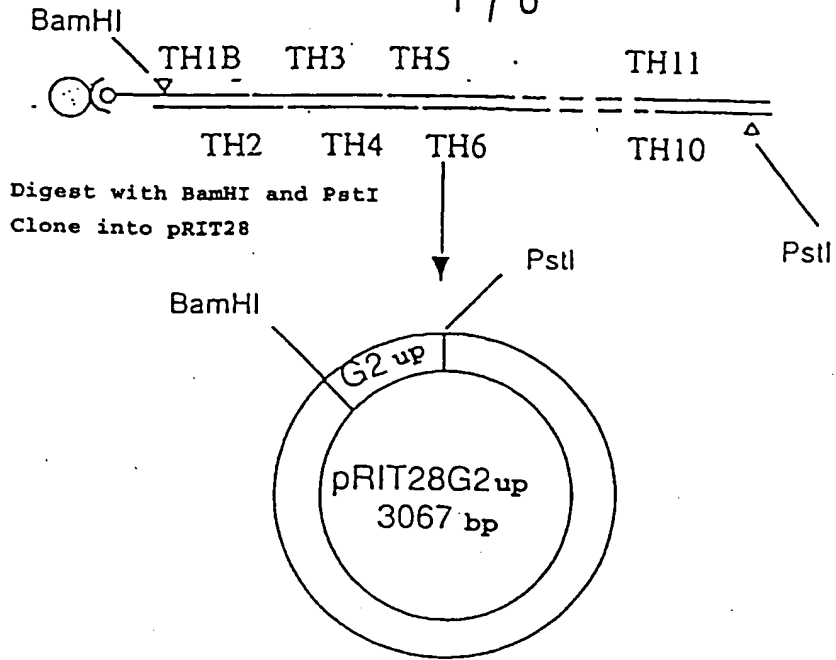

FIG. 1

2 / 8

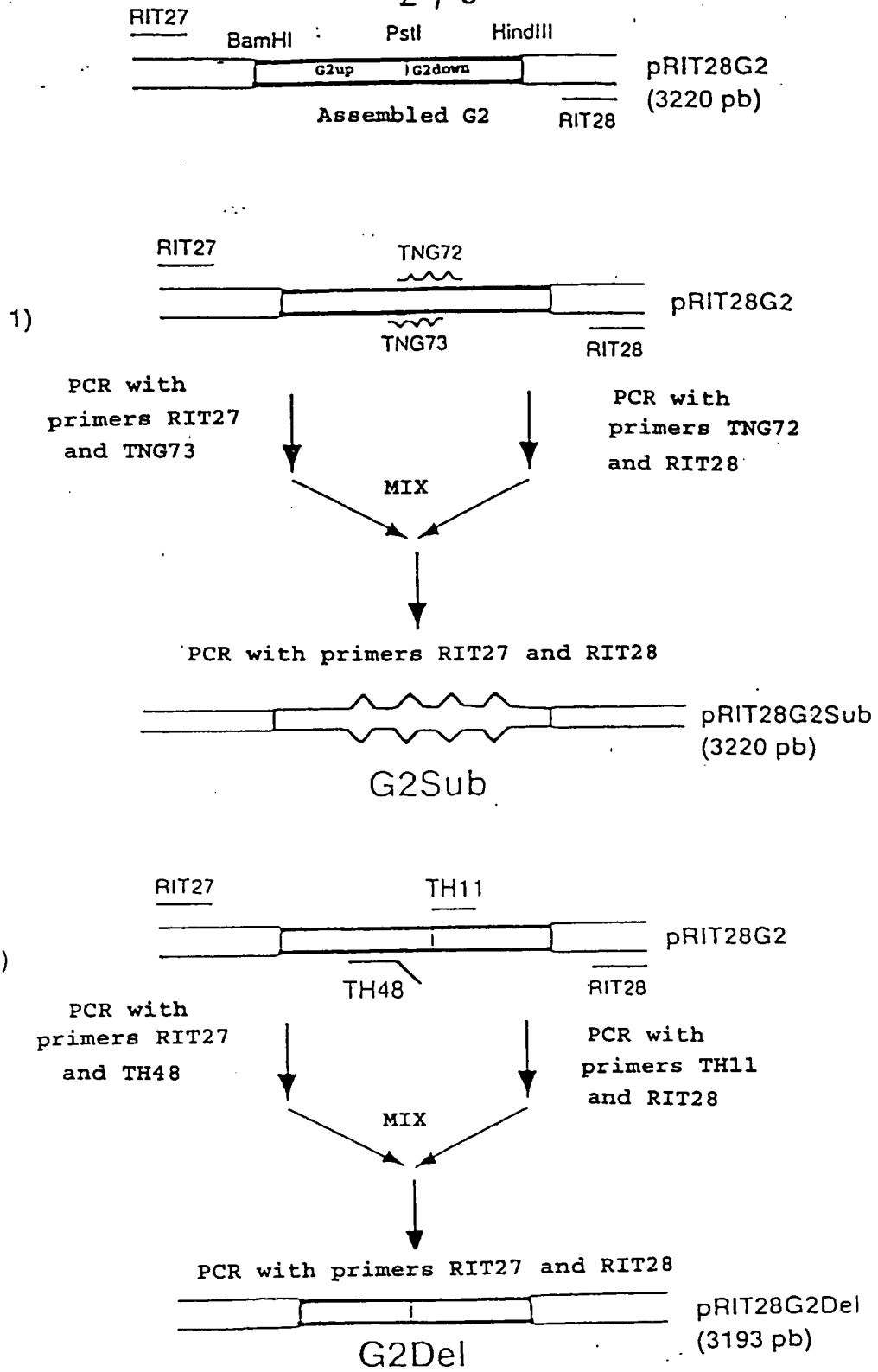

FIG. 2

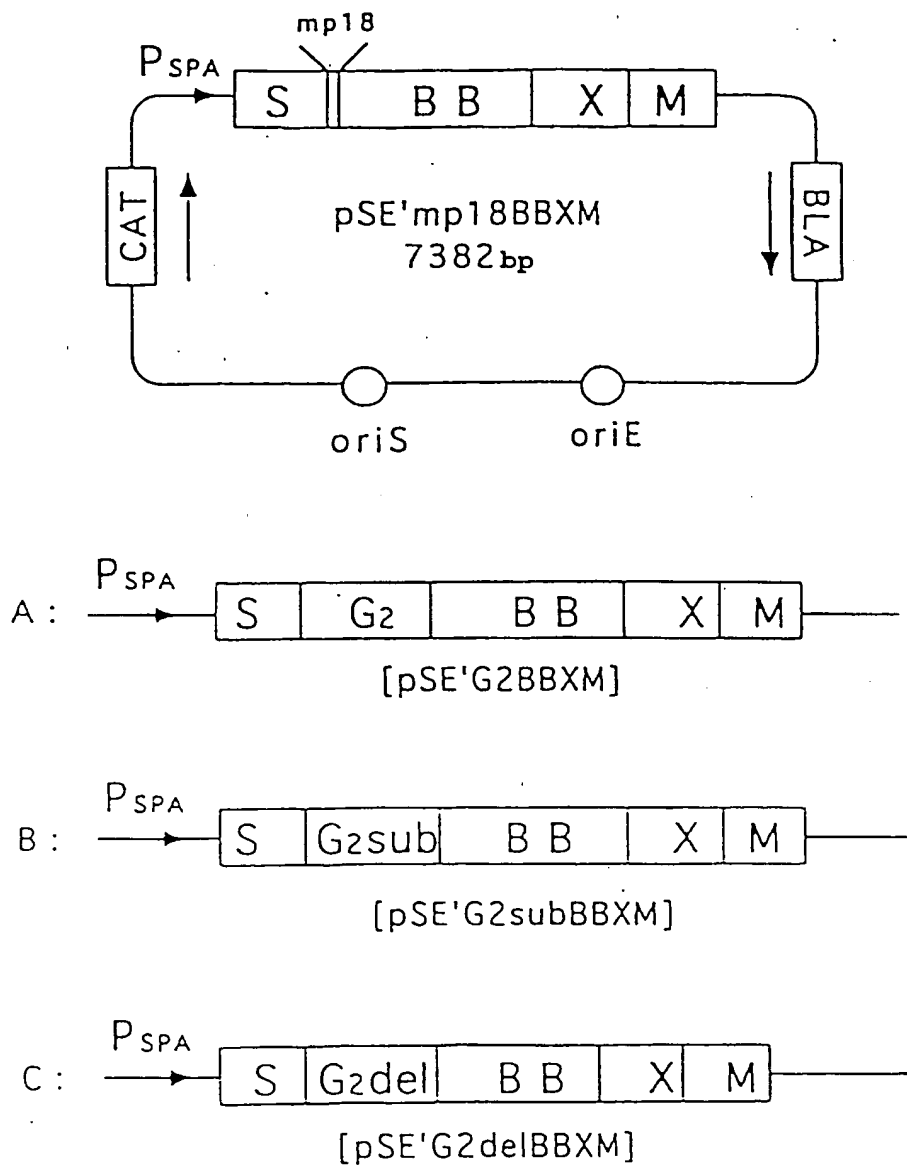

FIG. 3

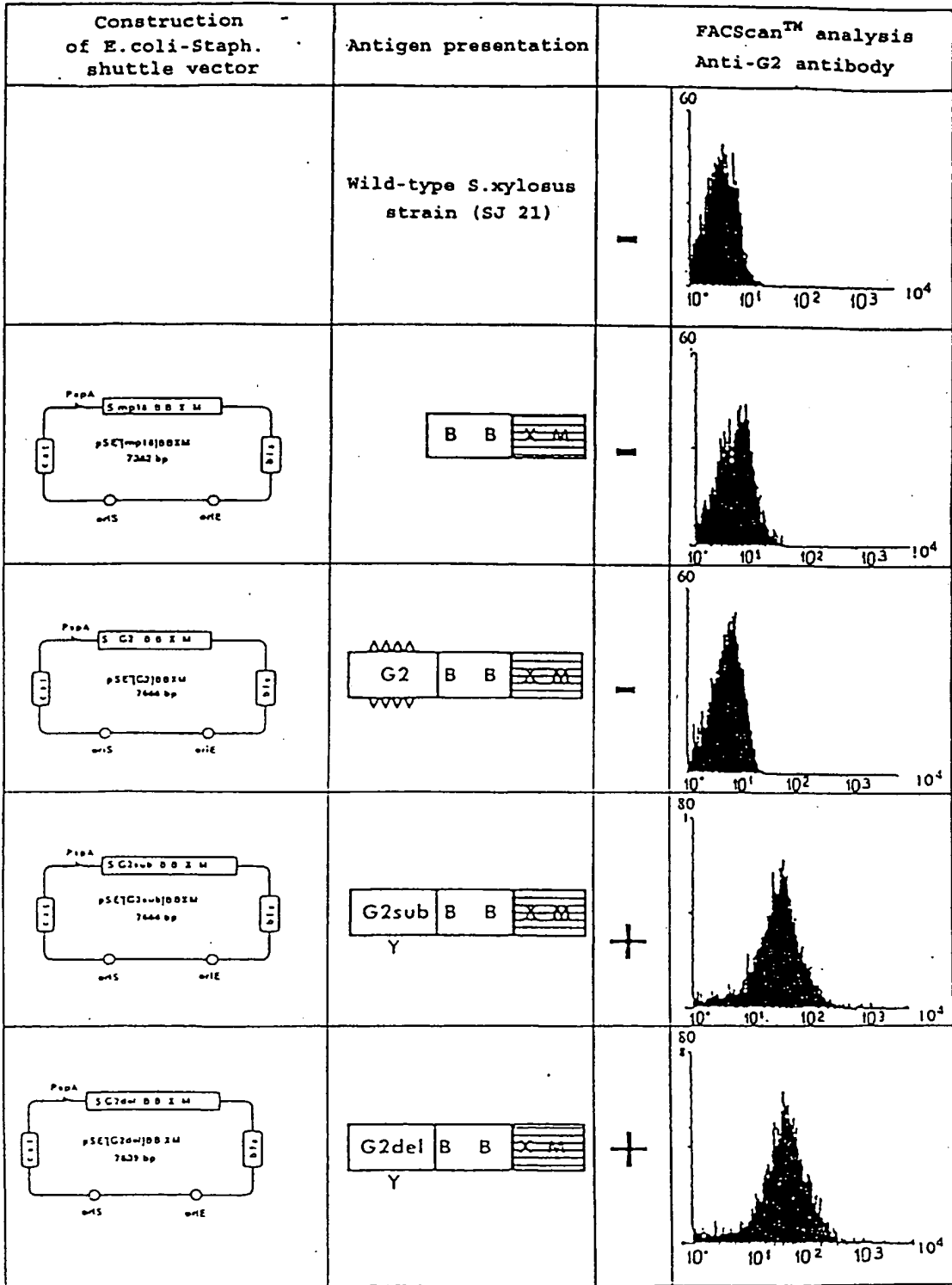

FIG. 4

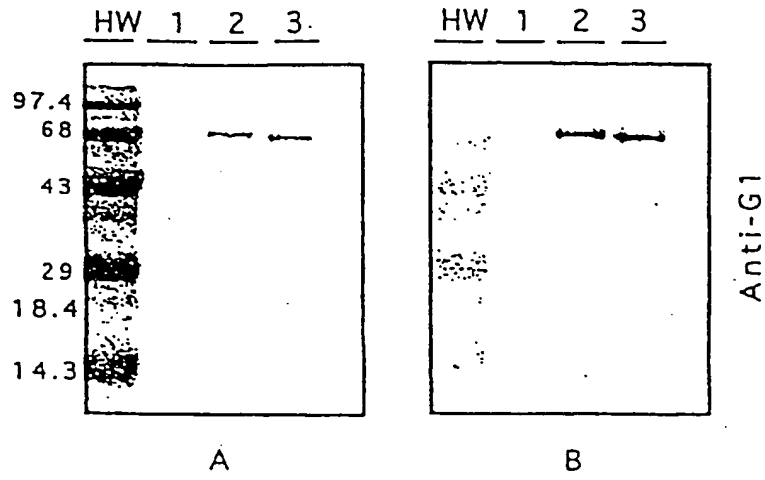

FIG. 5

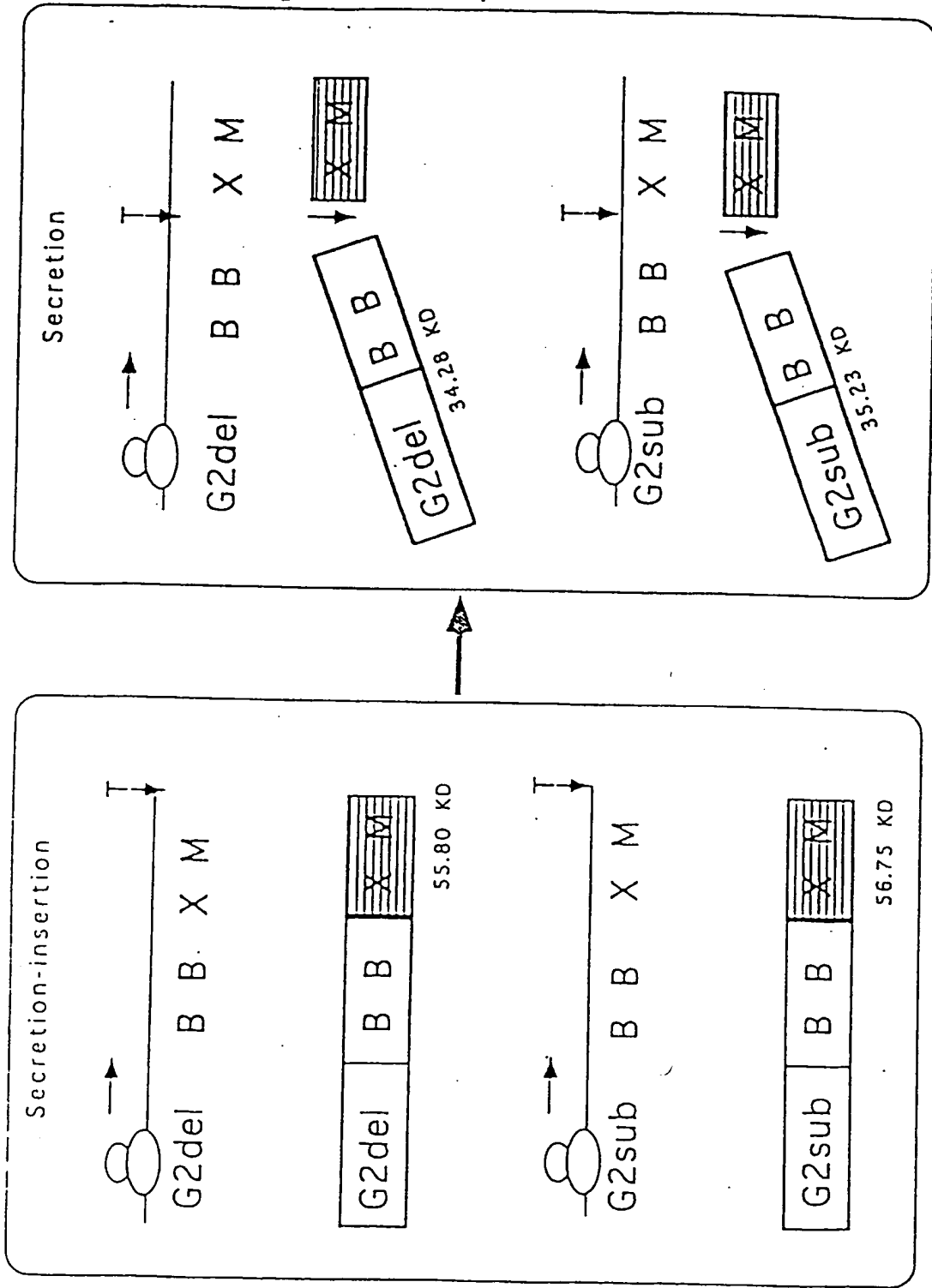

FIG. 6

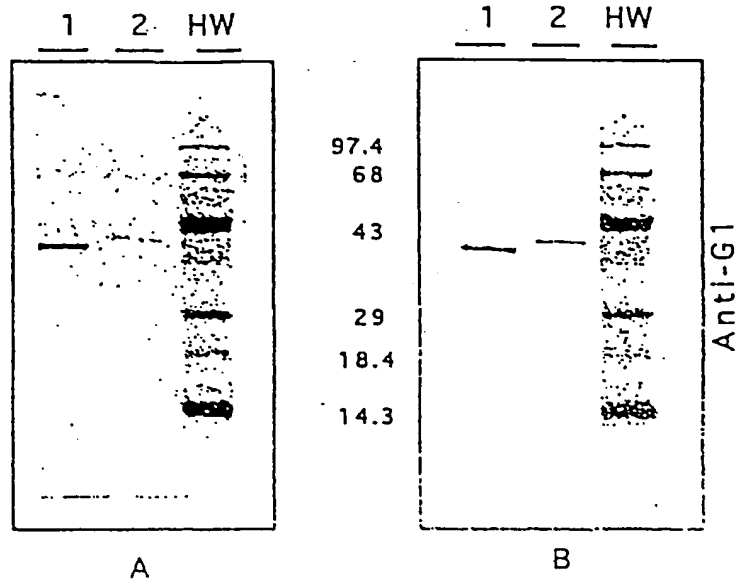

FIG. 7

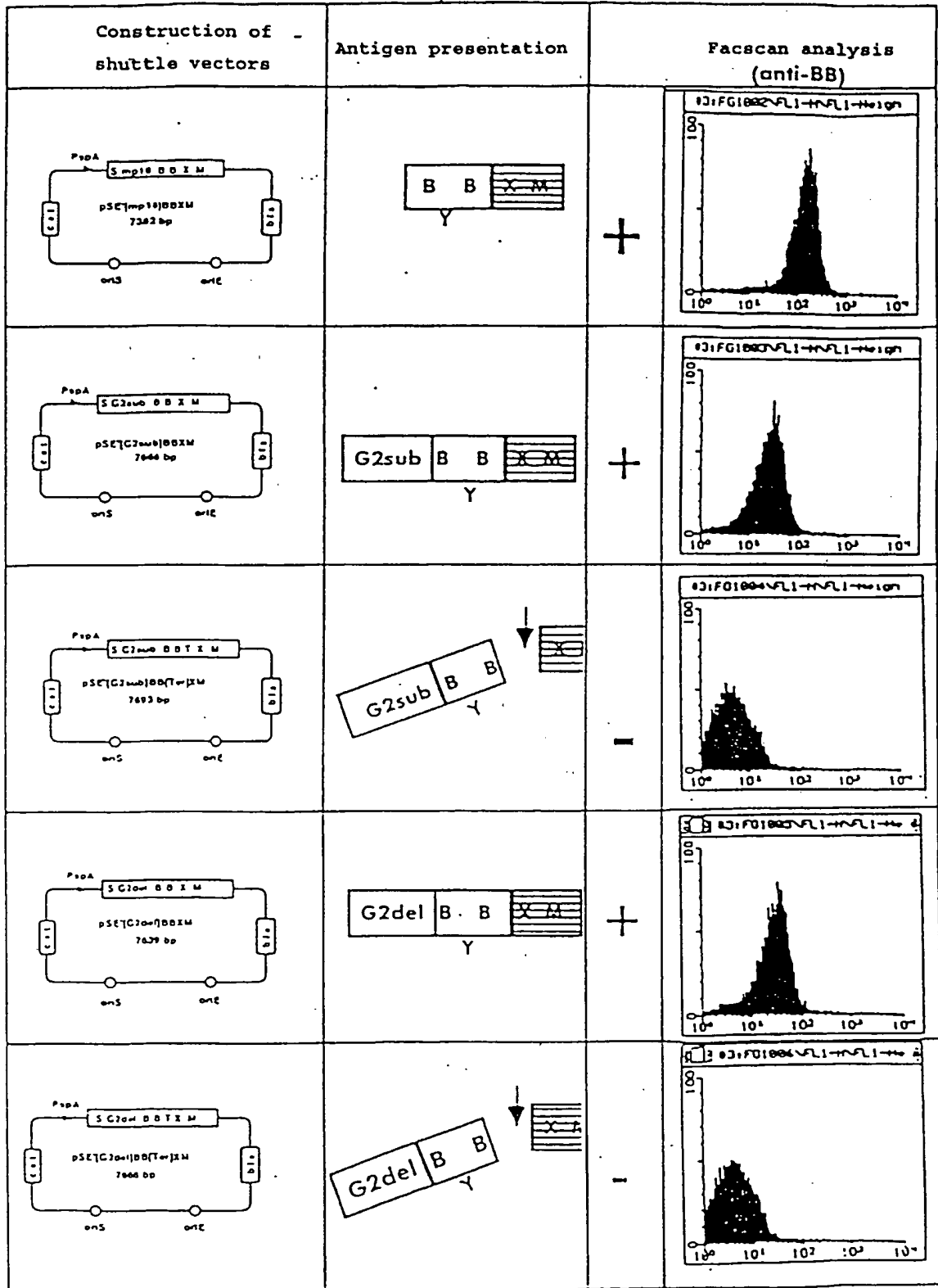

FIG. 8

**This Page is Inserted by IFW Indexing and Scanning
Operations and is not part of the Official Record**

BEST AVAILABLE IMAGES

Defective images within this document are accurate representations of the original documents submitted by the applicant.

Defects in the images include but are not limited to the items checked:

- BLACK BORDERS
- IMAGE CUT OFF AT TOP, BOTTOM OR SIDES
- FADED TEXT OR DRAWING
- BLURRED OR ILLEGIBLE TEXT OR DRAWING
- SKEWED/SLANTED IMAGES
- COLOR OR BLACK AND WHITE PHOTOGRAPHS
- GRAY SCALE DOCUMENTS
- LINES OR MARKS ON ORIGINAL DOCUMENT
- REFERENCE(S) OR EXHIBIT(S) SUBMITTED ARE POOR QUALITY
- OTHER: _____

IMAGES ARE BEST AVAILABLE COPY.

As rescanning these documents will not correct the image problems checked, please do not report these problems to the IFW Image Problem Mailbox.